

HDPE



**Weldable high-density polyethylene
for waste and drainage systems**



valsir[®]
QUALITY FOR PLUMBING



La Scala theatre - Milan (Italy)

HDPE

Valsir HDPE, the versatility of a waste system in high density polyethylene

Valsir HDPE is a fusion welded system made up of pipes, fittings and accessories, suitable for all installation types, destined to waste and rainwater drainage.

Valsir HDPE is the ideal solution for installations above ground, thanks to its resistance to UV light; and below ground or embedded in concrete, thanks to its exceptional mechanical characteristics.

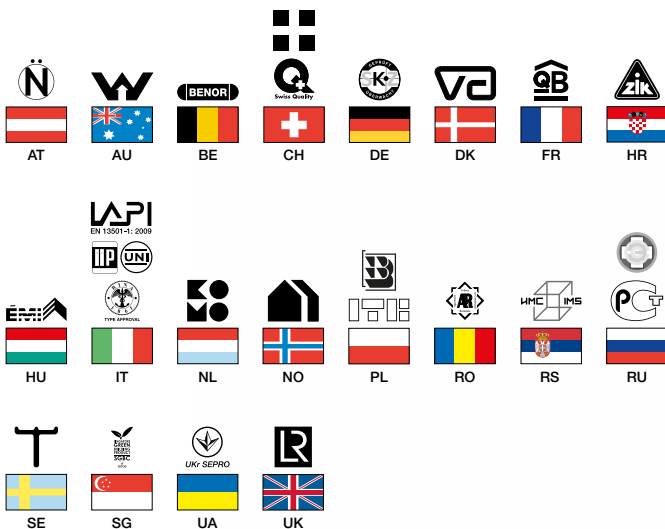

Valsir HDPE is produced in compliance with European Standard EN 1519 and can be used in **waste systems** at low (as low as -40°C) and high temperatures (up to +95°C), in ventilation systems of waste networks and for rainwater drainage **inside civil and industrial buildings, hotels, hospitals and laboratories** thanks to its high resistance to chemical compounds.

The wide range of pipes, fittings and accessories allows a complete waste system to be constructed, from the branches of the sanitary fixtures, to the soil stacks and soil manifold.

MADE IN ITALY



Left Bank - Birmingham (United Kingdom)

A SYSTEM WITH ADVANCED CHARACTERISTICS

The advantages of using Valsir HDPE waste system

- Wide range of **diameters from Ø 32 mm to Ø 315 mm**, available in **SDR 26** and **SDR 33**.
- The pipes are **stabilized** to reduce dimensional variations and contain carbon black for **UV light resistance**.
- Possibility of **prefabrication** to reduce assembly time on-site and possibility of creating **special pieces** for particular applications and solutions.
- **High chemical resistance** to substances dissolved in civil and industrial wastewater.
- Resistance to intermittent discharges at **temperatures as high as 95°C**.
- High resistance to extremely rigid temperatures as **low as -40°C**.
- **Excellent abrasion resistance** and mechanical strength.
- **Highly versatile and easily installed** thanks to its light weight and numerous connection methods that allow wastage to be reduced to a minimum.
- Wide range of transition fittings for connection to other waste systems such as cast iron, PE, PP, PVC.
- The product, its total recyclability and the production processes used are all based on the **Green Building principles**, respecting the environment and conserving resources.

High density polyethylene

The pipes and fittings are made of high density, UV light resistant, polyethylene that guarantees high **mechanical resistance**, excellent **abrasion resistance**, **extremely smooth surfaces** and high **resistance to chemical agents**.



The Valsir HDPE waste system has a high resistance to the most common chemical agents and has an extremely smooth internal surface which prevents the build-up of deposits within the waste network.

All Valsir HDPE pipes are stabilized to eliminate residual tensions caused by the production process and to reduce dimensional variations.



Ø32 Ø40 Ø50 Ø56 Ø63 Ø75 Ø90 Ø110 Ø125 Ø160 Ø200 Ø250 Ø315

SOLUTIONS FOR ALL REQUIREMENTS

The range is made up of 3 and 5 m length pipes, available in SDR 26 and SDR 33 and a wide range of fittings and accessories that allow the most varied system configurations to be constructed.

From a 32 mm diameter for creating branches, to a 315 mm diameter for waste manifolds.

The range is made complete with coupling accessories for connections to the other Valsir waste systems, anchor clips and all the equipment necessary for installation.



Fire collars

When fire protection standards or local regulations require the **compartmentalization of rooms** such as, for example, central heating plants, underground car parks and industrial facilities that are at risk of fire, then fire collars can be used.

To meet all system requirements and the most strict fire protection regulations **a complete range** is available that includes diameters **from 40 to 315 mm**. Polyethylene is combustible and in fire protection class B2 in compliance with DIN 4102 and in class E in compliance with EN 13501-1.

It is important to remember that the material that makes up the Valsir HDPE waste system is polyethylene and therefore, unlike other materials such as PVC, it doesn't produce carcinogens, such as dioxins and vinyl chloride in the event of fire.

ADVANCED SOLUTIONS



Valsir can **supply a waste system with a 110 mm and 160 mm diameter VBF (ventilation branch fitting).**

This is the ideal solution in high-rise buildings where the simultaneous use factor of the sanitary appliances is high.

This innovative waste system guarantees excellent ventilation of the waste stack and branches on each floor, limiting pressure fluctuations in the system.

This system also offers significant advantages in terms of money savings thanks to the possibility of constructing single stacks (therefore without installing parallel ventilation) in **one single diameter, either 110 mm or 160 mm with double the draining capacity** as compared to systems with primary ventilation.

The ideal solution in high-rise buildings

- **Single soil stack**, a parallel ventilation pipe is not required.
- **Increase in drainage flow** if compared to conventional systems.
- **Reduction in speed** of waste flow.
- **Excellent ventilation** of the stack and branches of each floor.
- **Up to 6 connections** on one branch fitting.
- **Up to 45* apartments** can be connected to the same soil stack with a **110 mm diameter** and up to **195* apartments** can be connected to a **160 mm diameter soil stack**.

* The number of apartments depends on the composition of the same.

A waste system with a Valsir HDPE “ventilation branch” allows greater volumes to be drained than any other waste system (primary ventilation systems, direct or indirect parallel ventilation systems,

secondary ventilation systems) thanks to the supply of ventilation air to the branches and the absence of return flows guaranteed by the special geometric configuration of the fitting.

System with primary ventilation

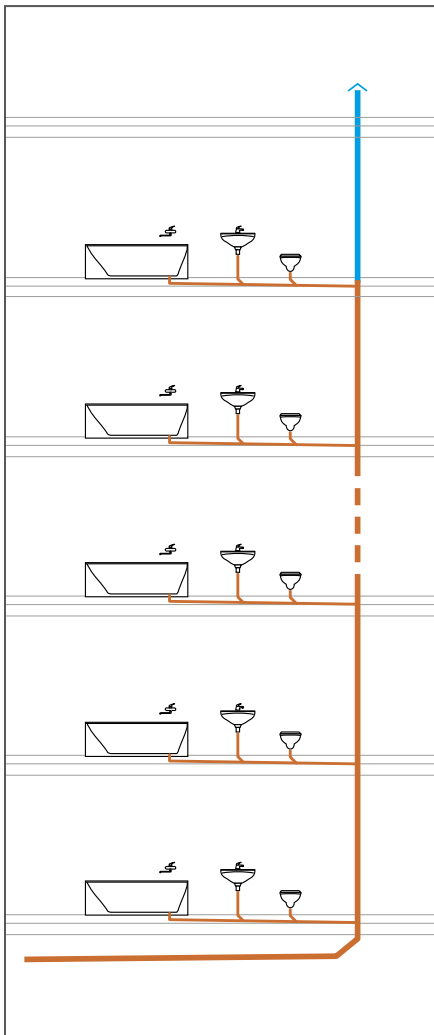

System with parallel ventilation

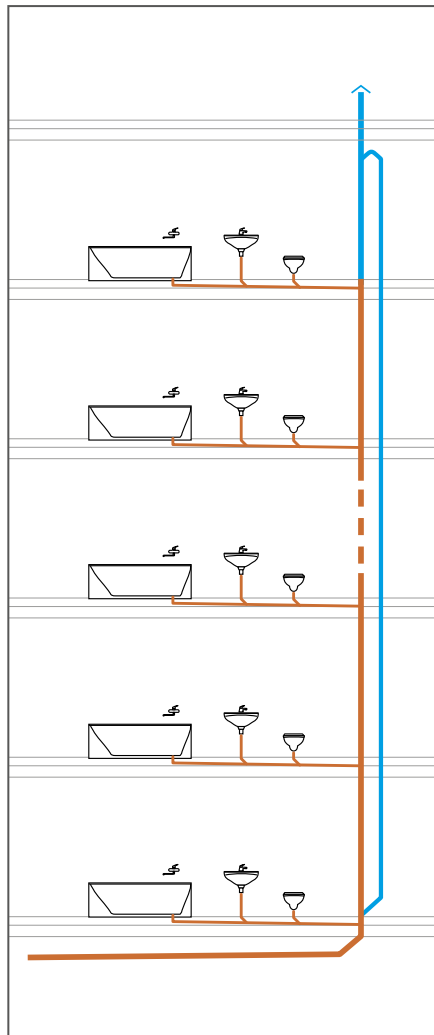

System with VBF

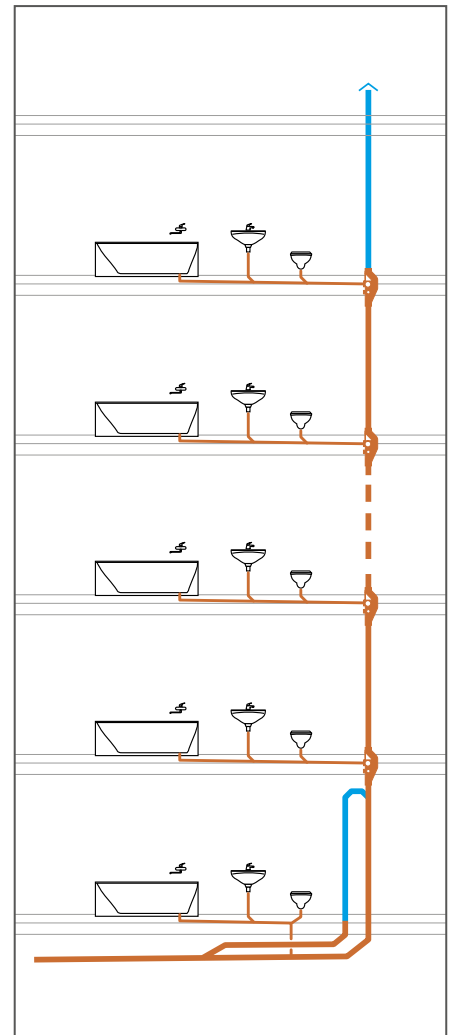

Drainage capacity **40% greater** than waste systems with primary ventilation.

Drainage capacity is **120% greater** than waste systems with primary ventilation.

EASE AND VERSATILITY OF INSTALLATION

Thanks to the numerous jointing systems Valsir HDPE guarantees an easy and versatile installation also due

to the possibility of prefabricating system parts and assembling them on-site.



Butt-welding

This jointing method allows the greatest savings in space. It is performed using a welding machine equipped with jaws, miller and heating plate. For diameters up to 63 mm, it can be done manually using a heating plate only. It is the most suitable welding method for the prefabrication of system parts to be assembled later on site.



Electrofusion couplings

This is the most practical method of jointing. It requires the use of a welding machine that supplies electricity to the sleeve to bring it to the point of fusion and to connect the pipes and/or fittings. This welding method acts on the external surface of the pieces to be welded without affecting the internal surface of the pipe.



Flange fitting

This jointing system is used to connect tanks or hydraulic appliances with flange connections. It is a removable joint and is stress-rupture resistant.



Screw thread fitting

This is a removable joint that is useful where system parts need to be connected together and practical and rapid removal is necessary. If it is not fitted with a collar then this type of joint will not supply stress resistance, and requires the pipe to be suitably anchored.

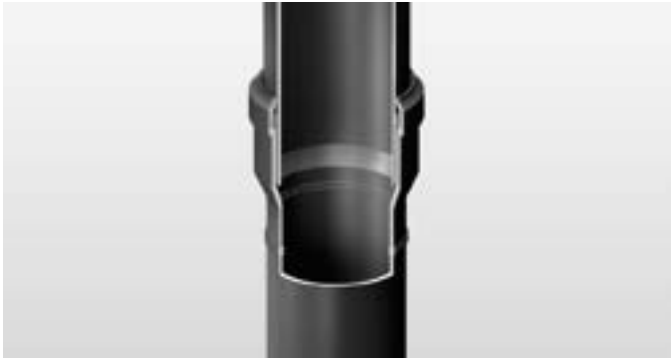

Ring seal socket

This jointing system uses a push-fit socket and seal to connect prefabricated system parts together. This type of joint does not provide stress resistance; it must therefore be used with a suitable system for anchoring the pipe.



Expansion sleeve

This jointing system incorporates a seal that is used to compensate any thermal expansion in the horizontal and vertical segments of the waste system. This type of joint does not provide stress resistance; it must therefore be used with a suitable system for anchoring the pipe.



Contraction expansion socket

This jointing system is suitable for connecting systems made of other materials to the polyethylene pipe, especially when the structure and surfaces are irregular. Water tightness is guaranteed by the seals in the joint; it is not stress resistant.

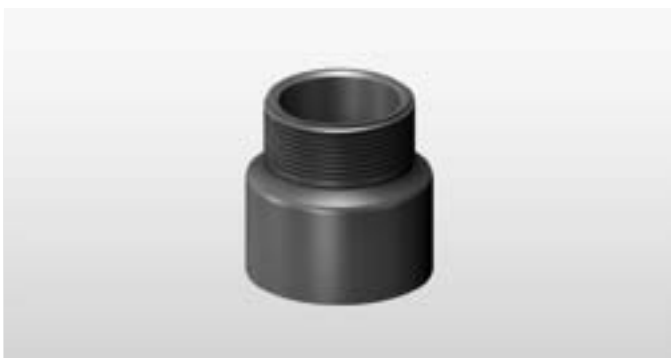

Threaded fitting

This jointing system is used to connect polyethylene pipes to threaded metal pipes. It is available both with a male or a female thread.



APPLICATIONS

Valsir HDPE is extremely easy to use, it offers numerous jointing methods and meets all installation requirements.

Valsir HDPE is used to construct drainage systems for waste water and rainwater in residential buildings and in collective buildings such as offices, hotels, hospitals, schools, police barracks, factories and sports centres.

Its excellent resistance to UV light allows surface mounting both indoors and outdoors.

Valsir HDPE can be embedded in concrete. In fact, thanks to its high elasticity, the mechanical stress that is induced inside the pipe wall by thermal expansion and contraction, is perfectly compatible with the mechanical resistance of the material itself.

Finally, thanks to its abrasion, impact resistance and flexibility, it can be used in the ground.





Valsir

Valsir D 250

PEHD



THE WELDING PROCESS

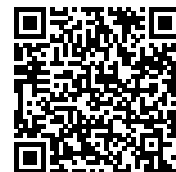

Watch the video



Manual butt-welding

Thanks to the extremely light weight of polyethylene, pipes and/or fittings up to a 63 mm diameter can be butt-welded using a manual process which involves the use of a heating plate only. It is an extremely convenient jointing method on site.



Machine butt-welding

Valsir supplies butt-welding machines that weld up to 315 mm diameters. This process is extremely useful for the prefabrication of system parts that are then installed and connected on site using the other numerous jointing methods, such as welding with electrofusion sleeves.



Electrofusion couplings

Thanks to the use of electrofusion couplers that are available in 40 mm diameters to 315 mm diameters, all system parts can be prepared. Valsir supplies two types of welding machines that guarantee rapid, easy and extremely reliable welding.

RAINPLUS[®], THE SYPHONIC RAINWATER DRAINAGE SYSTEM

Valsir HDPE pipes and fittings are an integral part of Rainplus[®], a syphonic rainwater drainage system designed to reach maximum drainage performance with the lowest levels of water accumulation on the roof.

Valsir's technological know-how fully meets increasingly heavier rainfalls, guaranteeing the drainage of medium to large size buildings in total safety.

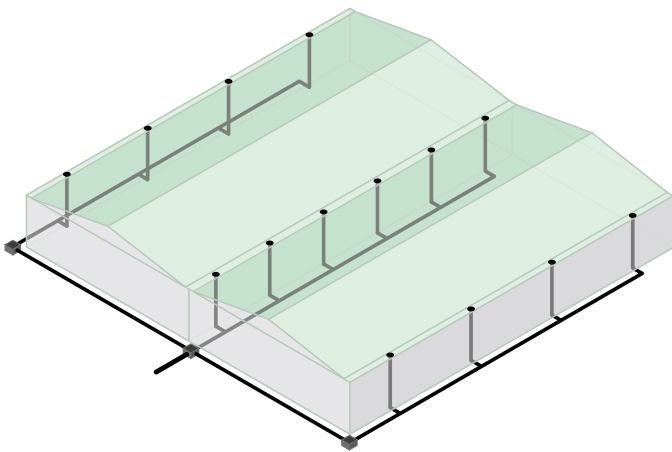

Conventional systems

- Collector pipes with slope.
- High number of outlets.
- High number of downpipes.
- Significant digging work.

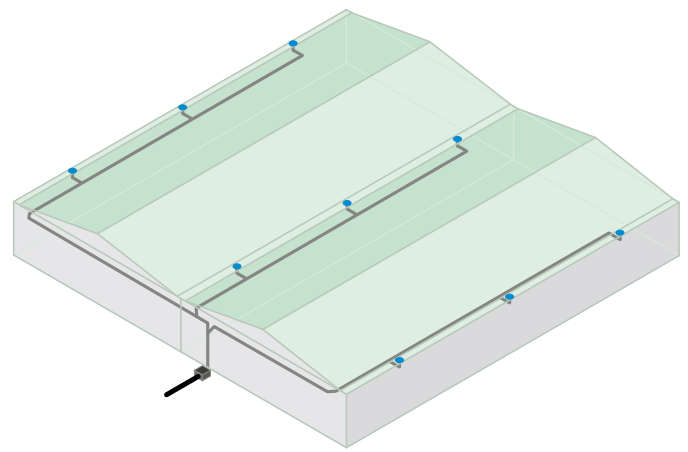

Rainplus system

- Fewer downpipes.
- Horizontal collector pipes.
- Limited digging.
- Fewer outlets.

Advanced technology in syphonic drainage

Rainplus[®] features the most up-to-date technology in the building sector and in rainwater drainage from the roofs of medium to large size buildings.

The system uses the building height as the driving force to generate high speed flow rates thus maximising drainage efficiency.

Rainplus[®] allows the entire flow of water to be directed to any part of the building whatsoever, thus allowing the most modern rainwater harvesting systems to be installed as required by the Green Building Program.

This technology offers numerous advantages, such as a significant reduction in costs and installation time as well as an increase in the performance of the entire drainage system.

- **Economical.** As compared with conventional systems, Rainplus® requires a fewer number of roof outlets and allows a substantial reduction in pipe diameters, in the number of fittings and downpipes required; savings of up to 80% are easily achieved on vertical pipes and from 20 to 30% across the entire system.
- **Space saving.** The roof outlets are connected to single horizontal collector pipes installed without fall and downpipes are positioned along the building perimeter thus avoiding interference.
- **High performance.** When in operation, pipes are full over the entire system, drainage velocity is therefore greater resulting in the self-cleansing action of the pipework.
- **Sustainability.** Given the greater ease in directing the pipes to storage tanks, collection of rainwater is facilitated for reuse in irrigation systems, fire ponds and tanks for non-potable uses in general.
- **Time saving.** Construction programmes are accelerated due to reduced installation time; moreover less groundwork is required due to the reduced number of embedded pipes.
- **Increased flexibility in planning.** Complete control over the positioning of downpipes and the absence of embedded collector pipes gives greater freedom in the definition and planning of a syphonic system.





Soul Apartments - Gold Coast (Australia)

REFERENCES



Arzanah Medical Complex - Abu Dhabi (United Arab Emirates)



Crowne Plaza - Abu Dhabi (United Arab Emirates)



David Promenade residences - Tel Aviv (Israel)



Le musée des Confluences - Lyon (France)



Vakkaru Island Resort - Male (Maldives)



Oman Exhibition and Convention Centre - Muscat (Oman)



CUSTOMER SERVICE

Technical support

Valsir provides complete support during design and on site, thanks to a high-level technical department that consists of a team of engineers with international experience that are capable of providing solutions to all installation needs.



Valsir Academy

Valsir has an important training facility - **Valsir Academy** - dedicated to clients, distributors, plumbers and planners that provides perfectly equipped courses, both theoretical and practical on the use and the design of plumbing and heating systems. Courses are provided both inside the training facility and on customers' premises.

SOFTWARE

Silvestro software

The design of floor and radiator heating systems, water supply as well as waste and drainage systems, is extremely easy and the issue of the technical documents is rapid when using the Silvestro software program. Rapid, simple, unique, Silvestro has numerous strong points:

- rapid learning curve thanks to a simple and intuitive interface
- completely graphic background that facilitates input of the project details
- automatic drawing of the loops in the floor radiant systems
- automatic repositioning of the stack points on the plan view
- generation of calculation reports that are exportable in an .xls format
- import and export of files in .dwg format
- immediate update of software with a guided procedure
- creation of complete bill of materials from the project files

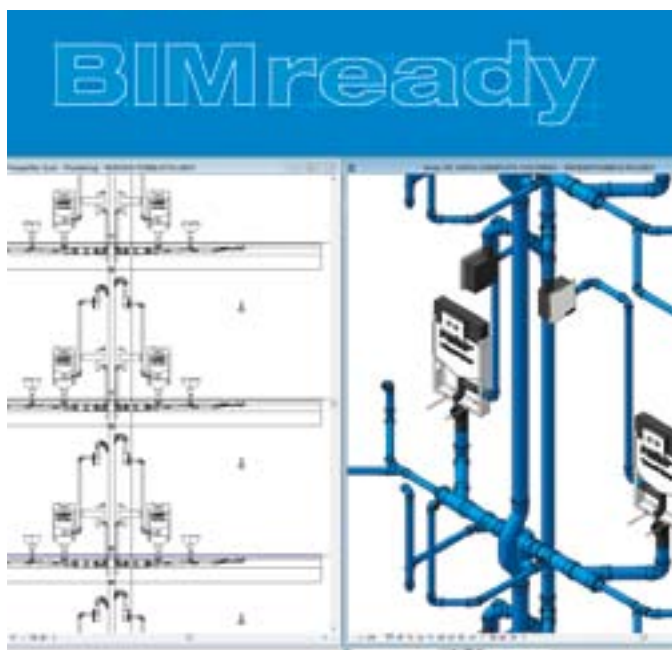

Valsir is BIM ready

Valsir has embraced the BIM philosophy, the modelling process that allows the improvement of planning, design, construction and the management of buildings, concurring with the transition of the industry toward the digital representation of buildings. “BIM oriented” planning offers extraordinary competitive advantages: greater efficiency and productivity, fewer errors, less downtime, lower costs, enhanced interoperability, maximum sharing of information, a more punctual and coherent supervision of the project. Valsir captures the essence of this system creating a series of Revit applications and models designed for simple and fast use.

QUALITY AND ENVIRONMENT

Quality

The ongoing commitment of Valsir to the creation of high quality products is demonstrated by over **200 product approvals** obtained around the world from the most strict certification bodies (figure updated on 01/02/2019), by the Quality Management System that is certified in compliance with **UNI EN ISO 9001:2008** and the Energy Management System that is certified in compliance with International Standard **UNI EN ISO 50001:2011**.

Valsir S.p.A. has further demonstrated its commitment to the environment obtaining the **ISO 14001:2015** certificate to the productive site in Vestone.



Sustainability

Efficient processes and reliable products are no longer the only parameters used to perform an assessment of the quality of a company's conduct: the capacity of the company and its management to design and implement production process that are sustainable from an environmental point of view is of equal importance.

Valsir has started a project of Corporate Social Responsibility and has published its 2nd Sustainability Report that gathers facts and figures relating to the daily commitment of Valsir in terms of social, economic and environmental responsibility.

For more information, download here the 2nd Sustainability Report.

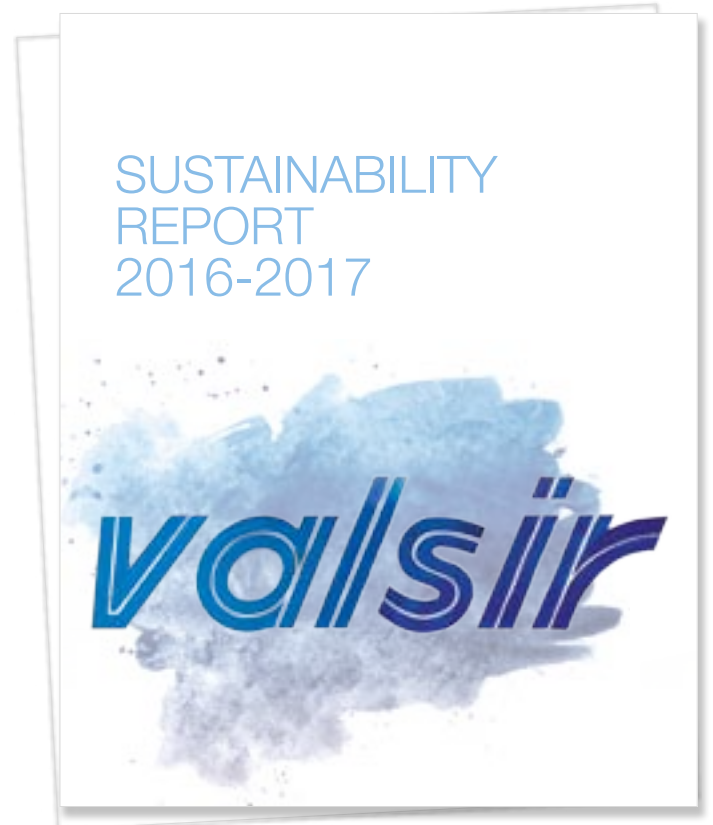

Download
valsir.it/u/sostenibilita-en

PLUMBING

WASTE SYSTEMS



SUPPLY SYSTEMS



GAS SYSTEMS



FLUSHING SYSTEMS



BATHROOM SYSTEMS



TRAPS



RADIANT SYSTEMS



DRAINAGE SYSTEMS



HRV SYSTEM



ACADEMY



SEWER SYSTEMS



WATER TREATMENT



BUILDING

valsir[®]
QUALITY FOR PLUMBING

VALSIR S.p.A. - Società a Socio Unico

Località Merlaro, 2

25078 Vestone (BS) - Italy

Tel. +39 0365 877.011

Fax +39 0365 81.268

e-mail: valsir@valsir.it

www.valsir.it

L02-536/2 - Febbraio 2019

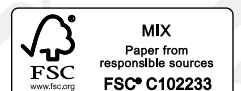

Soggetta all'attività di direzione e coordinamento ex art. 2497 bis C.C. da parte di Silmar Group S.p.A. - Codice Fiscale 02075160172